

# Application of wireless sensor networks in Mecsek mountain's caves

Beáta Muladi<sup>1,2</sup>, Zoltán Csépe<sup>1,2</sup>, László Mucsi<sup>1</sup>, Irén Puskás<sup>1</sup>

**Summary:** Modern speleology can profit from accurate measuring of cave climate components through long-time monitoring. Our aim is to test a set of new type of wireless temperature sensors in a cave environment. Apart from testing the new device we also want to demonstrate anthropogenic effects on the cave climate. The device is a low-cost and low consumption TELOSB wireless sensor module. The highly sensitive sensor records even the smallest changes in air temperature. These sensors are easy to manage. They allow continuous monitoring both in pits and horizontal passages of the cave and even to cover the whole extent of a cave. We measured the temperature in two caves in four time periods with 4 to 40 sensors. The number of sensors placed in a cave depends on the structure and morphology of the cave. Measurements were carried on in the warm and cold seasons and with different time spans. During the data evaluation, we checked the appropriate operation of the sensors. Our test sites were Trio Cave and Upper Szajha Cave in the Mecsek Mountains (southern Hungary). The purpose of the measurements is to survey the change in temperature caused by the visitors of the cave, depending on their number and the length of their stay in the cave. The time changes due to draft in a pit have also been investigated. From the data it can be seen that the visit of a group in the cave was accompanied by the quick rise in temperature, sometimes even more than 1 °C which returned to normal over a longer period of time.

## Introduction

The climate system in caves is very complex because of local morphostructure, air flow system and geopotential energies. Cave airflow is influenced by several factors such as surface temperature, cave temperature, atmospheric pressure, water conditions, cave morphology (horizontal or perpendicular passage), rock jointing, etc. (ROSE & NÉMETH, 1995). Cave temperature is a significant parameter since it can provide a lot of information.

Significant development in underground measurement techniques (modern electronic and other measuring devices) makes it easy to monitor cave climate.

Cave temperature measurements can be realized for scientific (characteristics of cave temperature) or practical (to discover unknown passages) reasons (RAJCZY, 2008). The present study addresses both viewpoints and can be summarized as follows:

- to test a wireless sensor network in order to determine its applicability in cave temperature measurement;
- to delineate the extent of surface temperature changes in a cave using short-term monitoring;
- to study air flow at the entrance and end-point of a cave;

- to monitor the increase in cave temperature caused by visitors and the duration to return to original temperature similar to investigations in Zichy-cave carried out (KAFFAI & IMECS, 2008).

## Sample area

A cave was selected in order to meet the following requirements: (1) No illumination, i.e. the cave is visited exclusively by speleologists and some adventure tourists with the leading of a specialized guide. (2) The cave space has to be small so that a change in temperature can be detected. (3) Horizontal and vertical passages or pits are present.

After considering the above criteria, the karstic region of western Mecsek Mountains (SW Hungary) was selected. Despite the small size of this area, several karstic formations and caves are found in lithologically homogeneous Triassic limestone. Different soil types covering the host rock presumably limit the air flow across micro fractures between cave and surface atmosphere. Cave research in this region is a rather difficult task since the host rock has been crumbled and moved along faults during the past 240 million years. However, the cave climate research is expected to reveal some of the main characteristics of the caves.

The Trió-cave in Szuadó valley is the seventh longest (255 m), and the second deepest (58 m) cave in Mecsek region. This typical swallowing cave in the valley floor has a temporary activity nowadays (BARTA, 2009). The cave can be morphologically divided into three parts. The first part from the entrance to the pit-system is narrow, with a gentle slope and about 30 m long. After

<sup>1</sup> Department of Physical Geography and Geoinformatics, University of Szeged, P.O. Box 653, Szeged, H-6720, Hungary

<sup>2</sup> Hungarian Speleological Society - Hungary, Budapest, H-1025 Pusztaszeri u. 35. Szeged Karst and Cave Research Association - Hungary, Orfű, H-7677 Barlangkutató u. 1.

passing the pit-system consisting of three perpendicular pits, you can get to a point where the cave divides into the Agyagos and Vizes branches (BAUER, 2010). The cave climate is dependant on its energy balance and energy exchange between cave and land surface. Thus, it is very essential to know surface climatic conditions typical of the given region. Trió-cave can be classified into the "colder static subtype" defined by FODOR (1981) as the cave has only one entrance and passages stretches towards the inner part of the mountain.

## Material and methods

The applied device, a TELOSB low power wireless sensor module (Crossbow's TELOSB RevB /TPR2420/), promotes IEEE 802.15.4/ZigBee wireless communication protocol in order to realize low data rate (Fig. 1). The radio module is able to operate at a data rate of 250Kbps in ISM 2.4Ghz band. The Antenna is mounted on motherboard, and its range might reach 15 m based on our measurements. The control is regulated by 8 MHz Ti MSP430 microprocessor with 10kB RAM. Several types of sensors are integrated into this device: temperature, light and humidity. The sensors have 1MB external flash for data logging, input/output peripherals, one push-button and three led lights. Data collection and programming can be solved via USB interface. The temperature sensor's accuracy is  $\pm 0,5$  °C and the its scale is 0,01 °C. The device supplies users with the capability of two interfaces to which more sensors and peripherals can be connected. TinyOS is a small, open-source, energy-efficient software operating system which supports large scale, self-configuring sensor networks. The device is powered by two LR6 batteries (CROSSBOW, 2004).

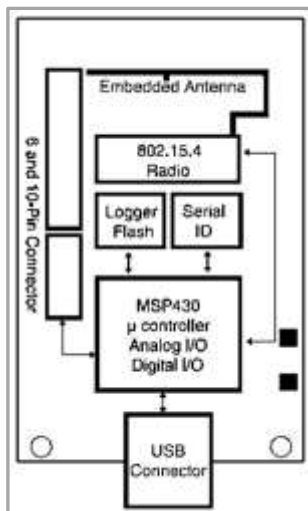

Fig 1: TELOSB sensor structure (Sources: Crossbow 2007).

Our system containing several TELOSB devices was used in the following way: temperature data were stored in every device, radio communication was established among the devices using base station controller for connecting the computer. This device was selected since it is small, wireless so it has not limited movement of visitors. The sensors can communicate up to 100 m at the surface. However, this distance is reduced to 20 - 25 m

in the underground depending on cave geometry. One device was supposed to be able to communicate with another one as far as 20 m using radio waves in Trió-cave. However, our assumption has not been confirmed as the farthest distance was only 12 m. Prior to measurements all the devices were calibrated, and the adjusted data were used during the analysis.

## Results and discussion

Evaluation of data measured in different caves

### Trió Cave

05.09.2010 4:20 pm - 07.09.2010 6:55 pm

The temperature was measured using four sensors during a research camp in 2010. The data were registered every five minutes by the sensors. One of four sensors (No. 4) was placed on a tree close to the cave entrance.

Three sensors were placed on different points in Tamás pit where the surface temperature was expected not to influence the cave. Sensors Nr. 1 and 2 were hung along the cave wall in Tamás pit and in the space between Tamás pit and a ledge (opposite to the ladder). Sensor Nr. 3 was mounted on ledge's crevice (Fig. 2). According to the preliminary measurements, it can be established that operation of sensors did not depend on their position (hanging or fixed to the wall).

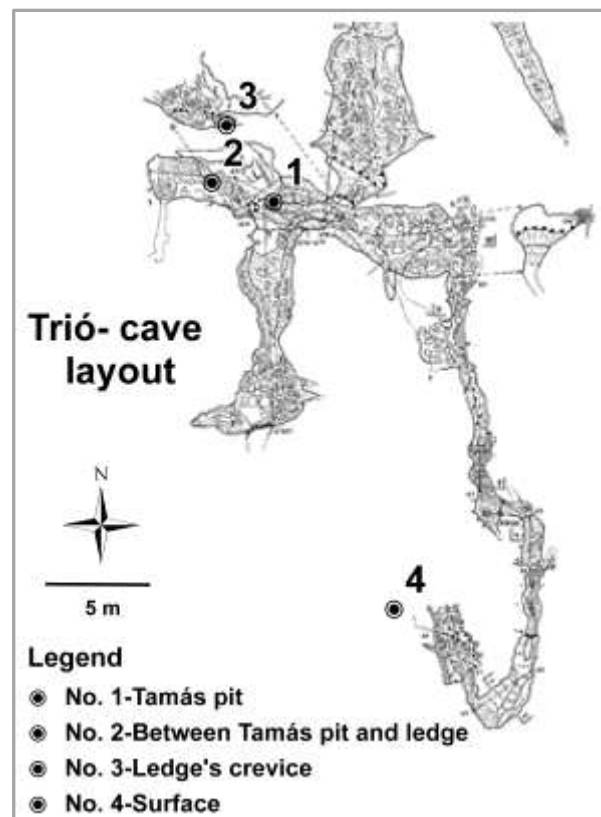

Fig. 2: Layout of the Trió-cave with the sensors (05 - 07. 08. 2010) (Based on SZKBE 2001-2002).

Descent into the cave, placement of sensors in Tamás pit took place at 4:20 pm, 5:30 pm, respectively. It took 20 minutes to ascend from the cave and then the surface sensor was placed at 5:50 pm. The temperature measured by the sensors fell from 16 to 10 °C within an hour, whereas surface temperature measured by sensor Nr. 4 increased from 16 to 19 °C in 25 minutes. The data of sensor No. 4 present clear temperature differences (14.5-20 °C) between nights and days. Furthermore, a sudden precipitation (13 mm) at 6 am, 06.08.2010 in Szuadó valley resulted in a temperature drop. However, the sensors in the cave have not indicated any significant temperature change during the observation period beside a clear temperature change in the cave when 12 visitors were staying there (Fig. 3.).

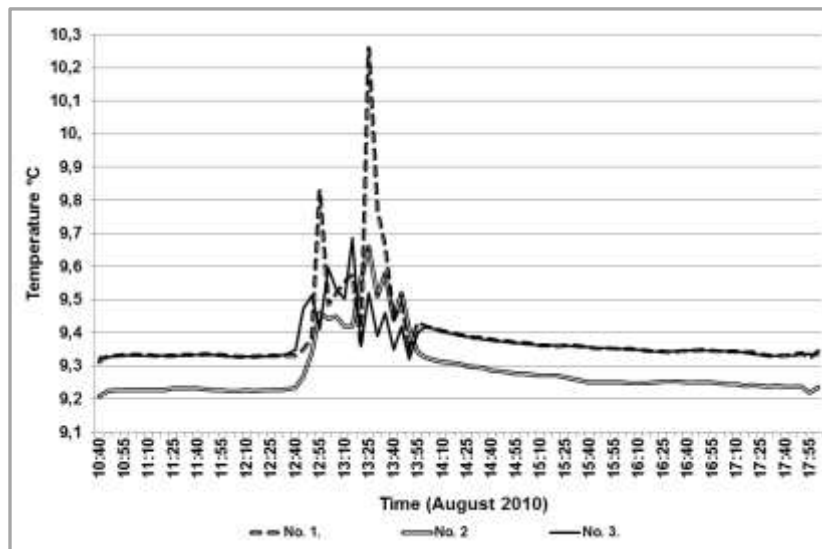

Fig. 3: Temperature rises measured by sensors due to the visitors (07.08.2010).

During our measurements, differences of some tenth of a degree among the sensors could be noticed. Although sensor Nr. 3 was put to a protected place, it recorded the temperature fluctuations.

The sensors Nr. 2 and 1 measured 9.2 °C as the lowest temperature. However, after the arrival of a group, sensor Nr. 1 showed the first and the most significant temperature rise (0.8 °C) as the first visitors were descending near to this sensor and staying there during 15 minutes. After the leaving of the visitors, temperature decreased by 0.3 °C in 20 minutes. On the way back, the visitors produced again an increase in temperature up to 10.3 °C at 1:25 pm. Temperature returned to 9.3 °C at 3:00 pm. However, this decrease was not uniform (Fig. 3.).

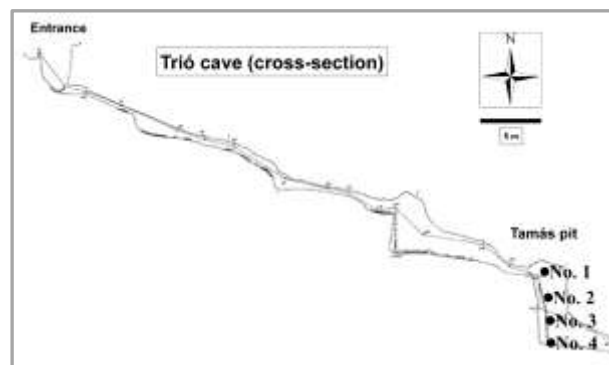

Fig. 4: Position of four sensors in Tamás pit.

### Tamás pit

24.02.2011 6:12 pm - 24.03.2011 7:12 pm

Four sensors were hanged into Tamás pit at equal distance along a rope (Nr 1, 2, 3, 4 from top to bottom of the pit) (Fig. 4). A surprising order of the temperature values can be noticed on figure 4: sensor Nr. 1, 2, 3, 4 measured 9.0; 9.3; 9.1; 8.6 °C, respectively. Data of sensor Nr. 4 and 1 are congruent with the expected: cold dense air settled at bottom of the pit, whereas warm air has risen to top. Data of sensors Nr. 2 and 3 contrast with our preliminary assumption, namely the temperature consistently decreases from top to bottom of the pit. In general, this pit is characterized by air layers with different temperature due to the presence of a branch that induces a turbulent flow around sensor Nr. 2, 3. As a consequence of this flow, warm air circulated around sensors Nr. 2, 3.

Considering monitoring data, it can be claimed Tamás pit is influenced by surface temperature diminishing below 0 °C in measured period (Fig. 5).

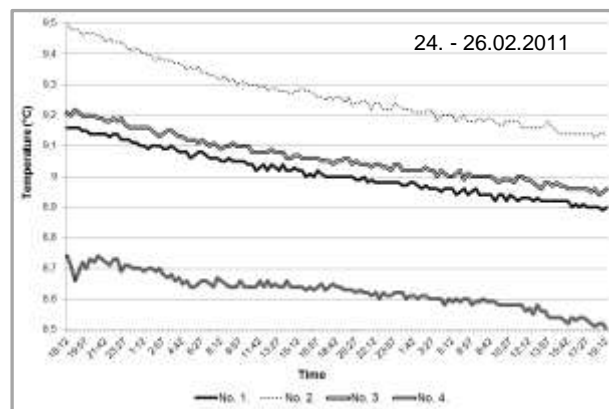

Fig. 5: Monitoring data measured by four sensors.

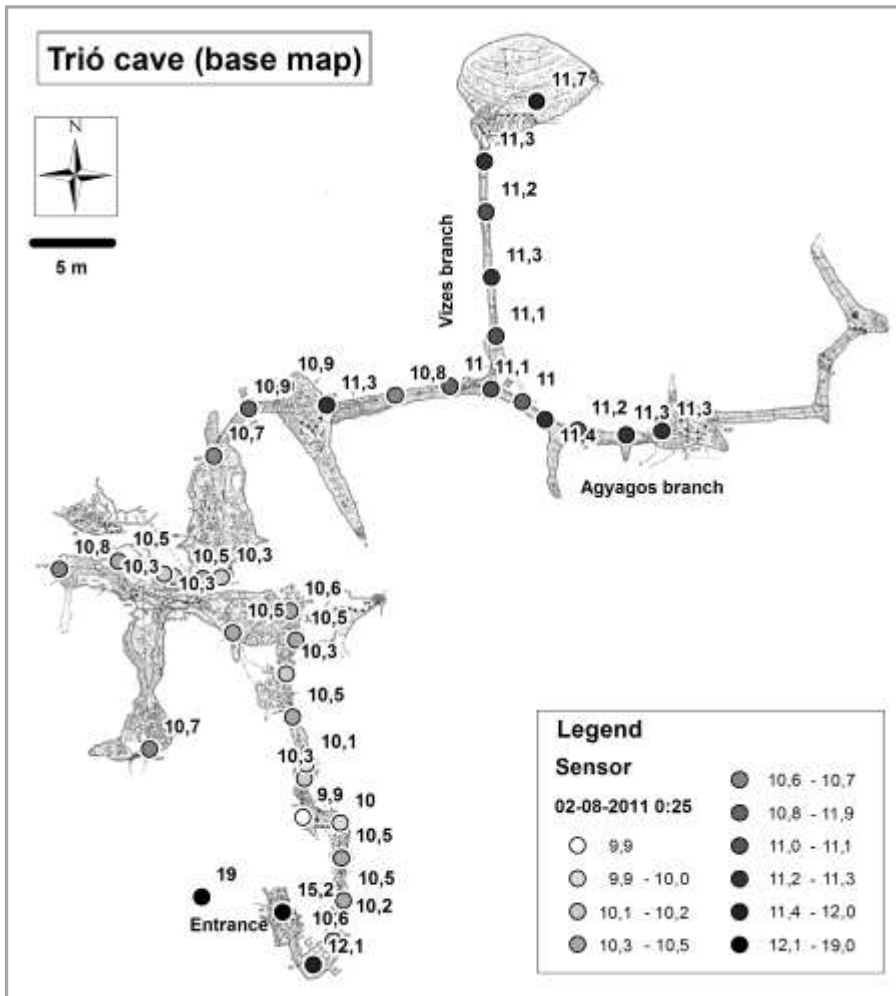

Fig. 6:  
Results of measurement  
in the Trió-cave using 40  
sensors (02.08.2011)  
(Based on SZKBE 2001-  
2002).

## Trió-cave

01.08.2011 5:25 pm - 06.08.2011 9:00 am

The temperature was measured all over the Trió-cave by 40 TELOSB sensors. The sensors were placed at the same height at various points in the cave in order to provide as much information as possible about the sampling site. If the temperature at the surface is higher than in the cave, surface air flows into the cave because of the low cave pressure (Fig. 6).

One sensor was placed outside the cave to register temperature differences in the valley. It is evident that surface temperature efficiently influenced stations at the cave entrance. Going deeper into the cave, from sensor Nr. 5, temperatures are clearly lower, about 10 °C at the bottom of „Gerinctörő”. The average temperature in the cave was 10.8 °C during the investigation period but differences can be detected in some parts of the cave. The temperature values can be divided into three categories similar to the above-mentioned cave morphological classification (KORDOS, 1970).

1. The first narrow, gently sloping entrance passage to the first pit is close to the surface and is the coldest part (average temperature is 10.2 °C) of the cave.
2. The second part is the pit-system where the air circulates due to chimney-effect (average temperature is 10.5 °C).

3. The third part can be divided into three regions:

- a. Because air flow cannot be perceived from the pit-system to the branch the temperature is higher (average value is 10.9 °C).
- b. Agyagos branch is filled up with clay material; average temperature is 11.2 °C.
- c. Vizes branch of “plum stone-shaped” made of rocks (average temperature is 11.3 °C).

A temperature change was detected on the 4th August when two groups were staying in the cave (Fig. 7). The main aim of this study was to get information about how many visitors cause a significant cave temperature change. The first group with 14 visitors stayed in the cave for 1 hour. This group induced different temperature changes in the respective parts of the cave. The highest increase in temperature (nearly 1 °C) was measured in the pit since the longest stay for visitors was here. The second group with 9 visitors exerted much less effect on temperature than the former group. Temperature maxima have been observed in the same points for both groups.

In both cases, temperature has risen very quickly, whereas it has returned to original level over a longer period of time. Consequently, it can be established that there is no heavy airflow in the cave (GÁDOROS, 1978).

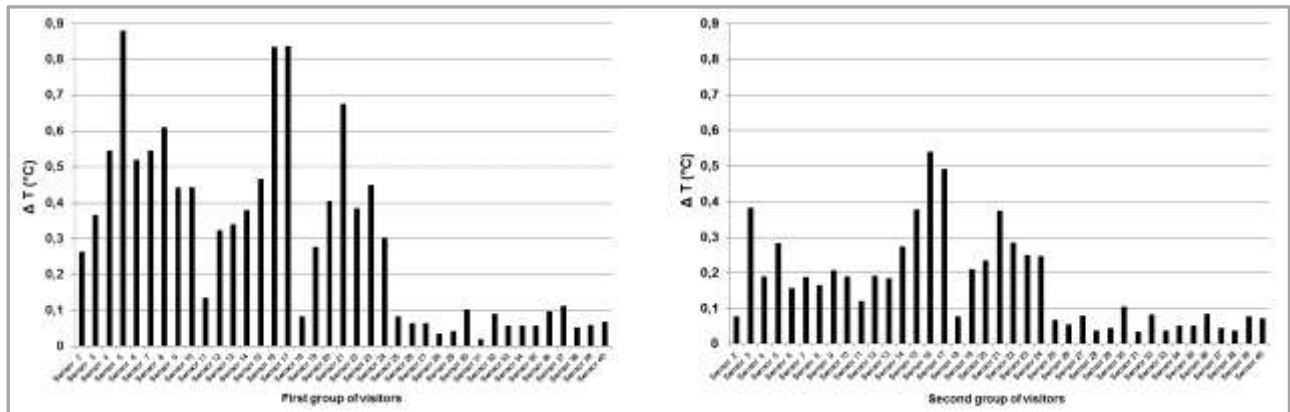

Fig. 7: Temperature changes due to two groups of visitors.

### Upper-Szajha Cave

22.01.2011 7:26 pm – 26.01.2011 8:32 am

The sampling area, Upper-Szajha cave, is located in a mountaintop south of Abaliget cave (KOLTAI et al., 2010). Twelve sensors were placed in the cave and one at ground surface, respectively. The sensors were placed along the horizontal part of the cave (Fig. 8).

Temperature data can be divided into four categories according to average temperature value.

1. Sensor Nr. 17 located at the beginning of horizontal passage (at the bottom of a pit) can be classified into the first category. Owing to this sensor position, the lowest temperature was detected here (11.5 °C). There is no temperature rise in this part of cave during visitor stay. This point is expected to be influenced by outside temperature.

2. Sensors Nr. 12, 14 and 16 belong to the second category (their average temperature is 11.5-11.8 °C). They were placed in a horizontal cave section (Depó, Táró-branch). Sensor Nr. 16 showed the highest value since this device was in the most protected position. The two warmest points coincide with this group of three sensors.

3. Sensors Nr. 9 and 6 belong to the third group. They were situated in Pandzsábi-double and Jackson conduit, respectively. Their average temperature is 12.1-12.2 °C. Sensors Nr. 9 showed a temperature rise owing to presence of three cavers. Sensor No. 6 shift has not detected any temperature change since nobody was there.

4. Sensors 8, 10, 11, 13, 15 and 19 can be classified into the fourth group; their average temperature ranged between 12.4 and 12.5 °C. A significant temperature drop could be observed because an air draft flows across a fracture system from the surface where the temperature was only 3.3 °C. Sensors No. 13 and 19, 11 and 8, and 10 and 15 were placed by couples at three locations. The highest temperature (13.6 °C) was detected by sensor Nr. 19 in relation to the research shift (between 09:26 am and 2:58 pm, 23.01.2011) at the end point. The temperature rise could not be noticed at sensor No. 13 located next to the end point since there was not research shift around this sensor. The temperature returned to its original value at various rates for each station.

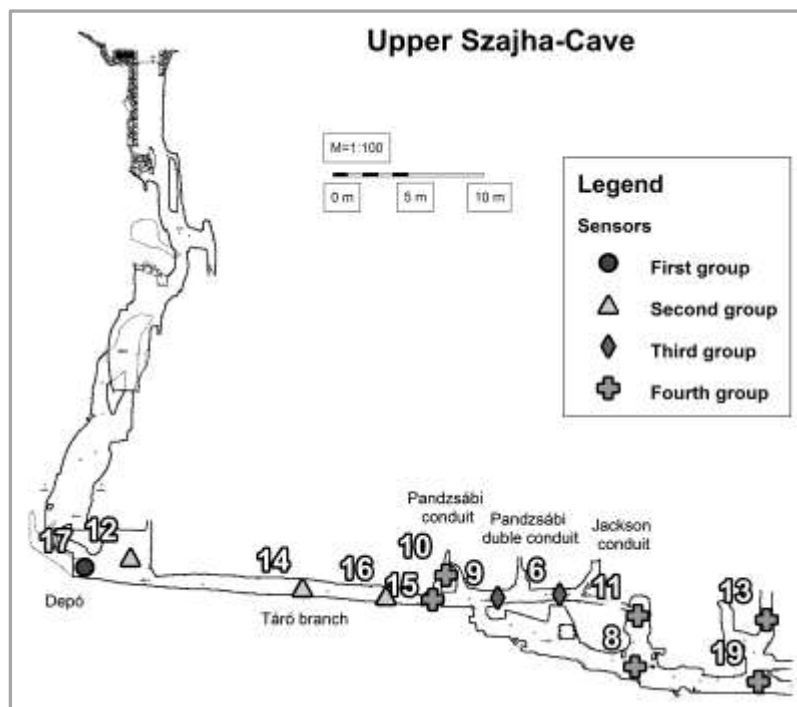

Fig. 8: Sensor location in the Upper Szajha-Cave (22 - 26.01.2011) (Based on: Zoltán Tegzes).

## Conclusion

In accordance with our results, it can be claimed that the wireless sensor network works reliably and accurately in caves. This device can detect even tiny changes in cave temperature; therefore it can contribute to the discovery of unknown passages.

Our study in Trió-cave demonstrated how artificial activities (mainly visitors) impact cave climate conditions: 9 and 14 visitors caused a 0.5 °C and 1 °C temperature change, respectively. As cave temperature is not uniform in caves, neither temporally nor spatially, microclimate measurements are fairly essential to get information about the maximum number of visitors that the cave can stand without a significant impact on its climate and ecosystem.

In the light of the above results, long-term data collection of other parameters (e.g. air quality) is planned in order to confirm our results. CO<sub>2</sub> concentration is impacted by visitors. It is controlled by cave ventilation and is a key component in controlling dissolution and precipitation processes in caves. This parameter is being further investigated in order to accurately reveal the influence of the visitors on cave CO<sub>2</sub> content and specify the ideal visitor number.

## References

- BARTA K. (2009): Terepi segédlet Nyugat-Mecseki-Karszt, Szeged, pp.1-9.
- BAUER M. (2010): A Szuadó-völgy barlangjainak kutatása IN. Beregi-Nagy E. (szerk.) SZKBE Hírmondó 38. szám, Kiadja a Szegei Karszt és Barlangkutató Egyesület pp.5-14.
- CROSSBOW (2007): Wireless Sensor Networks Product Reference Guide, USA pp. 42
- CROSSBOW (2004): TELOS B MOTE PLATFORM [http://www.willow.co.uk/TelosB\\_Datasheet.pdf](http://www.willow.co.uk/TelosB_Datasheet.pdf)
- FODOR I. (1981): A barlangok éghajlati és bioklimatológiai sajátosságai, Akadémia Kiadó, Budapest, pp. 168-169
- GÁDOROS M. (1978): A Hajnóczy-barlang mikroklimája, Karszt és Barlang I-II. füzet, Budapest, pp. 11-18
- KAFFAI O., IMECS Z. (2008): Mikroklimatológiai mérések a körösrévi Zichy-barlangban IN. Karsztfejlődés XIII. Szombathely, pp. 269-277.
- KOLTAI G., ORSZÁG J., TEGZES Z., BÁRÁNY-KEVEI I. (2010): Comprehensive Radon concentration measurements in caves located in the area of Mecsek mountains (Hungary), Acta Carstologica 39/3, Postojna, pp. 513–522,
- KORDOS L. (1970): Klímamegfigyelések a barlangok bejárati szakaszában, Karszt és barlang 1970. évf. I. füzet, Budapest, pp. 31-34
- KRAUS S. (2001): Barlangföldtan, Budapest, pp.151
- NYERGES M. (2006): Barlangklimatológiai alapismeretek <http://www.meander.hu/Barlangklimatologiaialapismeretek.pdf>, Budapest pp. 1-4.
- RAJCSY M. (2008): A barlangi klíma vizsgálata – IN. Dr. Lénárt L. és Vid G. (szerk.) Barlangi kutatásvezetői ismeretek, Budapest pp. 142-145
- ROSE GY., NÉMETH T. (1995): Barlangjárás alapjai- Barlangklimatológiai alapismeretek: <http://oktatás.barlang.hu/alapfoku-jegyzet/books/bgalap.pdf>, Budapest, pp.47-48.

## Acknowledgement

The authors want to thank to following persons for their help in the field: Márton Bauer, Éva Bujdosó, Zoltán Tegzes, Miklós Maróti.



This research was partially supported by the TÁMOP-4.2.2/08/1/2008-0008 program of the Hungarian National Development Agency.



Nemzeti Fejlesztési Ügynökség  
[www.ujszechenyiterv.gov.hu](http://www.ujszechenyiterv.gov.hu)  
06 40 638 638



A projekt az Európai Unió támogatásával, az Európai Szociális Alap társfinanszírozásával valósul meg.